

Olgiard MAŁYSZKO, Michał ZEŃCZAK¹

Zachodniopomorski Uniwersytet Technologiczny w Szczecinie,
Katedra Elektroenergetyki i Napędów Elektrycznych

Balance of Reactive Power in Wind Power Farm

Streszczenie. W artykule zaprezentowano problemy związane z mocą bierną w farmach wiatrowych. Typowa siłownia wiatrowa ma możliwość regulacji napięcia i poziomu generacji mocy biernej w pewnych granicach. Z drugiej strony istnieje dużo źródeł mocy biernej w farmie wiatrowej oraz na całej drodze przesyłu energii elektrycznej od farmy wiatrowej do systemu elektroenergetycznego (linie kablowe, linie napowietrzne). Dlatego utrzymywanie wymaganej wartości $\cos(\varphi)$ lub $\tan(\varphi)$ w punkcie przyłączenia farmy do systemu elektroenergetycznego jest dość skomplikowane. W artykule zawarto dokładną analizę tego problemu.

Keywords: wind power farm, reactive power, cable line, compensation of reactive power

Introduction

According to polish previous rules [1] wind power farms (WPF) should keep $\cos(\varphi)$ in the range $\cos(\varphi_{ind.}) = 0.975$ and $\cos(\varphi_{cap.}) = 0.975$. In new rules [2] this range is between $\cos(\varphi_{ind.}) = 0.95$ and $\cos(\varphi_{cap.}) = 0.95$. Typical wind power plant (WPP) has possibility of regulation of voltage and reactive power in some ranges. But such the regulation does not ensure required level of voltage and $\cos(\varphi)$ in point of common coupling (PCC) that is the bus bars of 110 kV in substation belonging to Power System. There are many sources of reactive power in typical WPF: generators, transformers 20/0.69 kV in WPP, 20 kV cable lines and transformer 110/20 kV. Besides WPF is connected to power system through the 110 kV line. There are two possibilities: overhead 110 kV line or 110 kV cable line. Figure 1 presents this typical solution.

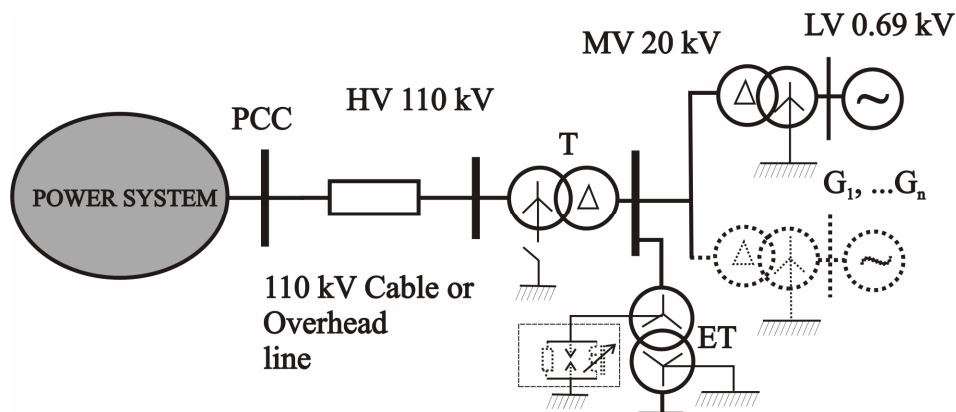

Fig. 1. Connection of typical WPF to power system

Typical WPF (tens of MW) covers big area and total length of 20 kV lines is about a few km or a dozen or so. Therefore the capacitive current is quite high. The distance between WPF and substation (PCC) can be dozen or so km (sometimes tens of km). Therefore the capacitive current can be high too, especially when the cable line is used. Such the line is the source of inductive reactive power about 0.5 Mvar/km.

Problems with regulation

The balance of reactive power depends on the level of generation of this power in many above mentioned sources. Generation of wind power plant (WPP) depends on the wind speed. Level of generation in cable lines depends on the voltage in the line. For example the level of voltage in 110 kV line should be in the range (105, 123 kV) [1, 2, 3, 4]. The reactive capacitive power is proportional to U^2 , therefore the power can change even about 37% ($(123/105)^2 = 1,37$). Besides the voltage is different in different points of lines. Transformers generate the capacitive reactive power, which depends on voltage in the same way.

The additional problems are created by reactive power depended on current. This capacitive reactive power is generated by inductive longitudinal elements in lines and in transformers. Thus the total balance of reactive power depends on many items. The balance may be positive or negative. Therefore the compensation of reactive power is necessary. The compensation of reactive power should be in both "directions" (inductive and capacitive) because of not only different levels of generation of reactive power in elements but also because of different character of reactive power.

The exact analysis is done for typical WPF. Many different variants (cable lines, overhead lines, different wind speeds) are taken into consideration. All elements are modeled as the four-terminal networks. Range of reactive power control by generators of WPP: ($\cos(\varphi_{ind.}) = 0.95$; $\cos(\varphi_{cap.}) = 0.95$).

Below the approximate method is used. In this method voltage losses are neglected. The results of both methods are compared.

Calculations for WPF connected with power system by 110 kV cable line

Exact calculation should take into account all elements. Fig. 2 presents exact electric diagram of 30 MW WPF.

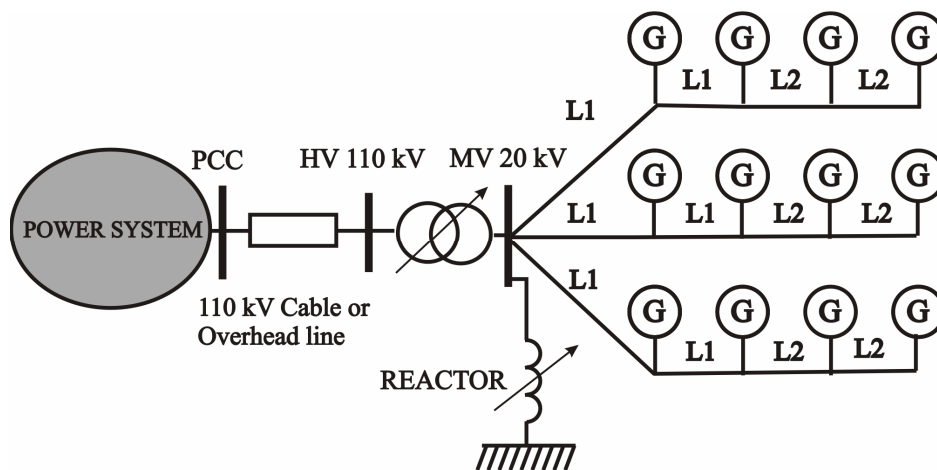

Fig. 2. Electric diagram of 30 MW WPF

VII Lubuska Konferencja Naukowo-Techniczna – i-MITEL 2012

The reactor in WPF should ensure compensation of reactive capacitive power of all elements in WPF. The voltage in WPF $U = 20$ kV is assumed to be const. Voltage of cable line (or overhead line) $U = 110$ kV is the same like in PCC and changes in range (105, 123) kV. The algorithm of control of reactor should be following:

- tap-changer controller of reactor reacts to value of voltage in PCC and compensates capacitive reactive power of lines,

- $\tan(\varphi)$ in PCC will be kept by the controllers of WPPs in range (-0,22; 0,22).

The parameters of elements are following:

- cable line 110 kV: copper, 3×150 mm², $l = 10$ km, $R' = 0.124$ Ω /km, $X' = 0,242$ Ω /km, $B' = 27.1$ μ S/km,

- transformer HV/MV: $S_n = 31.5$ MVA, $\vartheta = 115/20$ kV, $u_z = 10\%$, $\Delta P_{Cu} = 0.162$ MW, $\Delta P_{FE} = 0.0193$ MW, $I_0 = 0.5\%$, ($G_T = 48.25$ μ S, $Y_T = 393.8$ μ S, $B_T = -390.8$ μ S),

- cable lines 20 kV L1: $s_{L1} = 240$ mm², $R' = 0.125$ Ω /km, $X' = 0,110$ Ω /km, $B' = 94.2$ μ S/km, length of one cable line $L2 = 0.8$ km.

- cable lines 20 kV L2: $s_{L2} = 150$ mm², $R' = 0.206$ Ω /km, $X' = 0,116$ Ω /km, $B' = 78.5$ μ S/km, length of one cable line $L1 = 0.8$ km,

Reactor should compensate reactive power of WPP in no-load running. Total capacitive reactive power of 20 kV lines for $U_{MV} = 20$ kV:

$$(1) \quad Q_{LMV} = -U_{MV}^2 B_{0LMV} = -0.332 M \text{ var}$$

Inductive reactive power of transformer HV/MV in no-load running:

$$(2) \quad Q_T = -U_{MV}^2 B_T = 0.156 M \text{ var}$$

Capacitive reactive power of 110 kV cable line:

$$(3) \quad Q_{LHV} = -U_{HV}^2 B_{0LHV} = -3.71 \cdot 10^{-4} U_{HV}^2$$

The voltage of 110 kV can change in range (105 kV, 123 kV). Therefore the capacitive reactive power of 110 kV cable line has the range ($Q_{\min} = -4.09$ Mvar; $Q_{\max} = -5.61$ Mvar). If there is no reactor, the WPP in no-load running is the big consumer of capacitive reactive power:

$$(4) \quad Q = Q_{LMV} + Q_{LHV} + Q_T$$

For $U = 105$ kV: $Q = -4.266$ Mvar, while for $U = 123$ kV: $Q = -5.786$ Mvar. If the reactor with constant $Q = 5$ Mvar were used, the WPP would be still reactive power "consumer" (inductive or capacitive). The better solution is reactor with tapped variable induction:

$$(5) \quad Q_R = Q_{R0} + k Q_{RSI}$$

Where: Q_R – total power of reactor, Q_{R0} – minimal power of reactor, Q_{RSI} – reactive power of one stage of reactor, $k = 0, \dots, k_{\max}$ – number of tap.

Reactor should compensate the total reactive power of WPP:

$$(6) \quad Q_{LMV} + Q_{LHV} + Q_T + Q_R = Q_{LMV} + Q_{LHV} + Q_T + Q_{R0} + kQ_{RSI} = 0$$

The best results of control are when Q_{R0} is equal to reactive power of WPF for $U = 105$ kV:

$$(7) \quad -Q_{\min} = Q_{R0} = 4.266M \text{ var}$$

The number of tap k can be estimated by the formula:

$$(8) \quad k = \text{round} \left(\frac{3.71 \cdot 10^{-4} \cdot U_{HV}^2 - 4.09}{Q_{RSI}} \right)$$

Where $\text{round}()$ is the closest integer to value from brackets.

Calculations for WPF connected with power system by 110 kV overhead line

The different results are obtained for overhead line. The parameters of 110 kV overhead line are following : $l = 10$ km, wire AFL 6-240, $R' = 0.124 \Omega/\text{km}$, $X' = 0.41 \Omega/\text{km}$, $B' = 277.1 \mu\text{S}/100\text{km}$. Transformer and cable lines 20 kV are the same.

Reactor should compensate reactive power of WPF in no-load running. Total capacitive reactive power of 20 kV lines for $U_{MV} = 20$ kV is $Q_{LMV} = -0.332$ Mvar. Inductive reactive power of transformer $Q_T = 0.156$ Mvar.

Capacitive reactive power of 110 kV overhead line:

$$(9) \quad Q_{LHVOL} = -U_{HV}^2 B_{0LHVOL} = -2.77 \cdot 10^{-5} U_{HV}^2$$

The voltage of 110 kV can change in range (105 kV, 123 kV). Therefore the capacitive reactive power of 110 kV overhead line has the range ($Q_{\min} = -0.305$ Mvar; $Q_{\max} = -0.419$ Mvar). If there is no reactor, the WPF in no-load running is the consumer of capacitive reactive power:

$$(10) \quad Q = Q_{LMV} + Q_{LHVOL} + Q_T$$

For $U = 105$ kV: $Q = -0.481$ Mvar, while for $U = 123$ kV: $Q = -0.595$ Mvar. If the reactor with constant $Q = 0.54$ Mvar were used, the WPF would be reactive power "consumer" (inductive or capacitive) still. The better solution is reactor with tapped variable induction like for the cable line. Reactor should compensate the total reactive power of WPF:

$$(11) \quad Q_{LMV} + Q_{LHVOL} + Q_T + Q_R = Q_{LMV} + Q_{LHVOL} + Q_T + Q_{R0} + kQ_{RSI} = 0$$

Using the same principle like for cable line ($Q_{R0} = 0.48$ Mvar) the number of tap k can be estimated by the formula:

$$(12) \quad k = \text{round} \left(\frac{2.77 \cdot 10^{-5} \cdot U_{HV}^2 - 0.305}{Q_{RSI}} \right)$$

VII Lubuska Konferencja Naukowo-Techniczna – i-MITEL 2012

Values of “k” from formula (12) are different then from formula (8), because 110 kV cable line has much more bigger capacitance than 110 kV overhead line.

Results of exact calculations

Above presented calculations did not take into consideration many essential items. Therefore in order to check accuracy of calculations three different models were analyzed.

The first model (I) takes into considerations only susceptances of HV line, MV lines and transformer HV/MV. This model was used in above presented calculations.

The second model (II) takes into considerations all susceptances and longitudinal parameters of HV line, MV lines and transformer HV/MV. All elements are modeled as the four-terminal networks. Current flows, voltage drops, power losses were calculated. Besides the voltage regulation by HV/MV transformer was analyzed too. But model II does not take into considerations generators and transformers in WPP.

The third model (III) takes into considerations all susceptances and longitudinal parameters, voltage regulation by HV/MV transformer, generators and transformers in WPP, current flows, voltage drops and power losses.

Table 1 presents comparison of those models for 110 kV cable line. P and Q are active and reactive power consumed by WPP in PCC for no-load running.

Table 1. Results of calculations for three models for 110 kV cable line

Model	I		II		III	
U [kV]	P [MW]	Q [Mvar]	P [MW]	Q [Mvar]	P [MW]	Q [Mvar]
105	0	-4.266	0.019	-4.262	0.082	-4.177
123	0	-5.786	0.020	-5.779	0.083	-5.692

Fig. 3 presents the results of calculation of $\tan(\varphi)$ in PCC for 110 kV cable line where all elements are modeled as the four-terminal networks and the voltage is equal to 105 kV. Fig 4 presents the same but for the voltage 123 kV.

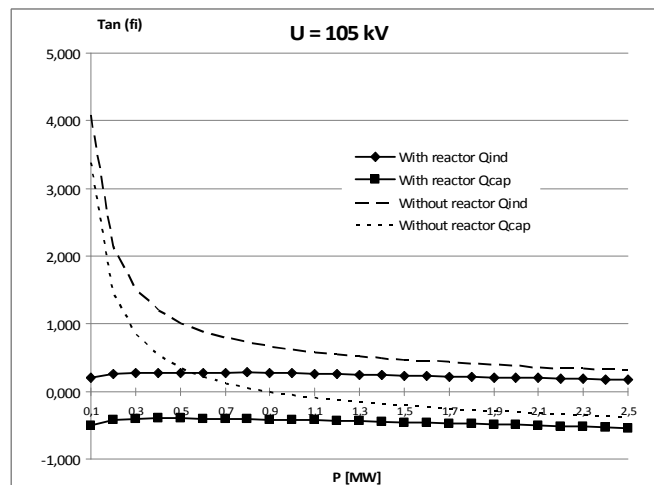

Fig. 3. $\tan(\varphi)$ in PCC as the function of power of WPP for cable line (voltage 105 kV)

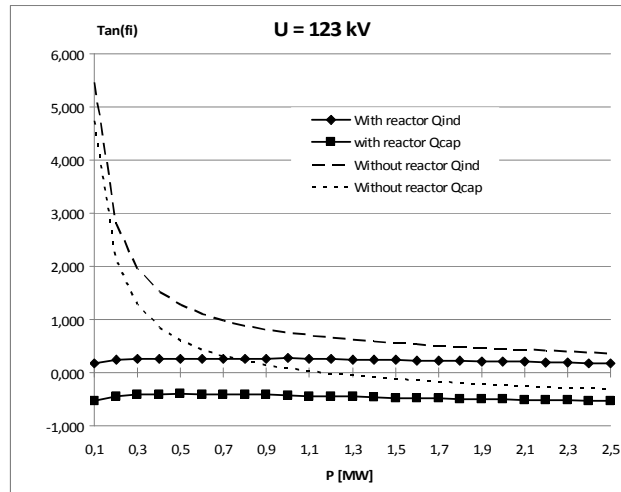

Fig. 4. $\tan(\phi)$ in PCC as the function of power of WPP for cable line (voltage 123 kV)

The same calculations were done for HV overhead line. Table 2 presents the results of calculation for three models.

Table 2. Results of calculations for three models for 110 kV overhead line

Model	I		II		III	
U [kV]	P [MW]	Q [Mvar]	P [MW]	Q [Mvar]	P [MW]	Q [Mvar]
105	0	-0.481	0.019	-0.477	0.082	-0.392
123	0	-0.595	0.019	-0.593	0.083	-0.507

Fig. 5 presents the results of calculation of $\tan(\phi)$ in PCC for 110 kV overhead line where all elements are modeled as the four-terminal networks and the voltage is equal to 105 kV. Fig. 6 presents the same but for the voltage 123 kV.

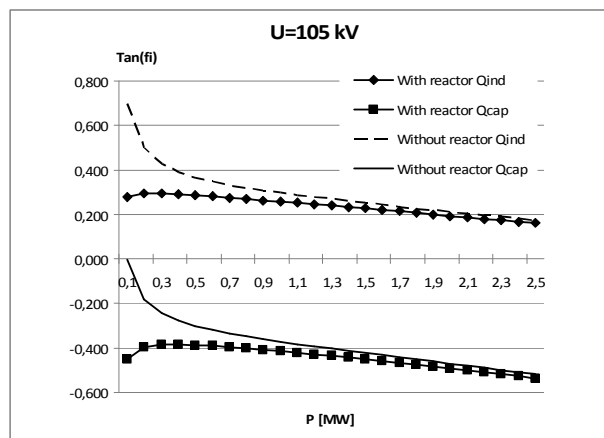

Fig. 5. $\tan(\phi)$ in PCC as the function of power of WPP for overhead line (voltage 105 kV)

VII Lubuska Konferencja Naukowo-Techniczna – i-MITEL 2012

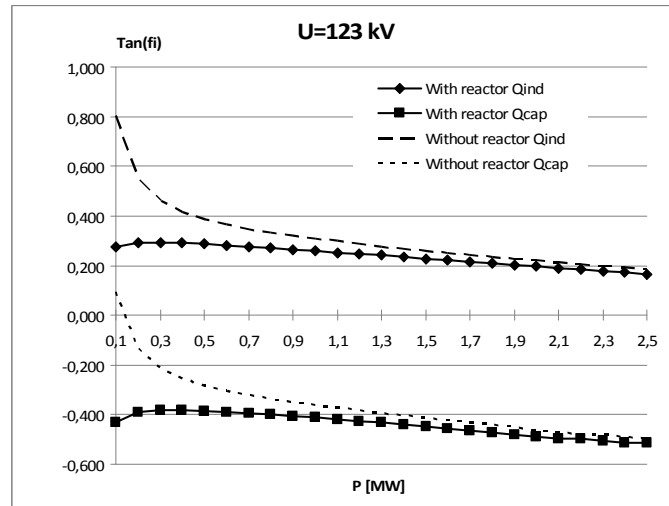

Fig. 6. $\tan(\varphi)$ in PCC as the function of power of WPP for overhead line (voltage 123 kV)

Conclusions

WPF is in no-load running the consumer of capacitive reactive power, therefore reactor should be used. Reactor makes possible keeping $\tan(\varphi)$ in required ranges.

In order to estimate power of reactor and algorithms of its work the model I is sufficient for cable line (error less than 2.5%). The main advantage of model I is possibility of calculation without computer. Model II and III require application of computer with complicated software. Calculation for overhead line should use exact models (II or III).

References

1. Instrukcja ruchu i eksploatacji sieci przesyłowej z dnia 5 listopada 2007 roku: „Warunki korzystania, prowadzenia ruchu, eksploatacji i planowania rozwoju sieci”. Polskie Sieci Elektroenergetyczne Operator S.A. (Instruction book of operation of transmission network)
2. Instrukcja ruchu i eksploatacji sieci przesyłowej: „Warunki korzystania, prowadzenia ruchu, eksploatacji i planowania rozwoju sieci”. Tekst jednolity obowiązujący od dnia: 1 lipca 2011 r. Polskie Sieci Elektroenergetyczne Operator S.A. (Instruction book of operation of transmission network)
3. Instrukcja ruchu i eksploatacji sieci dystrybucyjnej. 3 lipiec 2008, EnergiaPro S.A. (Instruction book of operation of distribution network)
4. Rozporządzenie Ministra Gospodarki z dnia 4 maja 2007 r. w sprawie szczegółowych warunków funkcjonowania systemu elektroenergetycznego, Dziennik Ustaw RP, 2007, Nr 93, poz. 623 (Polish rules)

Autorzy: dr inż. Olgierd Małyszko, dr hab. inż. Michał Zeńczak; Katedra Elektroenergetyki i Napędów Elektrycznych Zachodniopomorskiego Uniwersytetu Technologicznego w Szczecinie, ul. Sikorskiego 37, 70-313 Szczecin, e-mail: olgierd.malyszko@zut.edu.pl
michal.zenczak@zut.edu.pl